



液晶显示模组规格书

SPECIFICATION FOR LCM MODULE

客户名称(Customer Name) :	
客户料号(Customer P/N.) :	
模组型号(TCC P/N.) :	SYB12864AZKV20-5C11YLN2R-B5NG
物料编号(TCC C/N.) :	
文件号(Version No.) :	A0
日期(Date) :	2010-5-30

公司签核 (Signature)	管理者 (Manager)	市场 (Sales)	工程 (Engineering)	品保 (QA)

客户确认 (Customer approval)	
-----------------------------	--

- ※ 本公司承诺所销售产品的品质与所送样品一致
We promise that our products conform to the sample furnished in quality.
- ※ 若对试样产品的品质有特殊要求，请与本公司销售工程师联系。
In case of any special requirement on the quality, please feel free to contact our sales engineers.
- ※ 感谢您给予本公司送样承认的机会，烦请将此表签回本公司便于归档。
Thanks for awarding this opportunity of sample approval, please return this form to us for filing after authentication.

目 录 Contents

1 · 模组规格 Functions & Features	2
2 · 机械尺寸 Mechanical specifications	2
3 · 原理框图 Block diagram	2
4 · 模组外形图 Dimensional Outline	3
5 · 接口定义 Pin description	3~4
6 · 极限参数 Absolute Maximum limit	4
7 · 电性参数 Electrical characteristics	5
8 · 光电特性 Electrol-Optical characteristics	5
9 · 时序特性 Timing Characteristics	6~12
10 · 指令程序显示 Program instruction	13
11 · 品质保证 Quality Assurance	14~19
12 · 注意事项 Precaution for using LCD/LCM	20~21
13 · 附件一:参考程序 Reference Program for LCD Modules	22~24
14. 附件二: 控制器芯片资料	25

版本记录 Revision History

版本 Revision#	日期 Date	描述 Description	编制 Organizer
A0	2010-05-30	初始 Original	Jany

1、模组规格 Functions & Features

视角 Viewing direction	6:00		
LCD 模式 LCD mode	STN, Yellow-Green 黄绿模, Positive 正显, Transflective 半透		
驱动方式 Driving scheme	占空比(Duty) : 1/64 偏压比(Bias) : 1/9		
背光颜色 Backlight color	白光 White		
驱动电压(VDD)	5.0V	LCD 电压(VLCD)	6.5V
工作温度 Operation temp	-10~60°C	储存温度 Storage temp	-20~70°C

2、机械尺寸 Mechanical specifications

项目 Item	尺寸 Dimension	单位 Unit
显示容量 Number of Characters	128X64	Dots
模组尺寸 Module size	113.0(L)* 65.0(W)* 13.0(H)max	mm
可视区域 Viewing area	73.0 (L)*39.0(W)	mm
点间距 Dot pitch	0.45(L)*0.45(W)	mm
点大小 Dot size	0.50(L)*0.50(W)	mm

3、原理框图 Block diagram

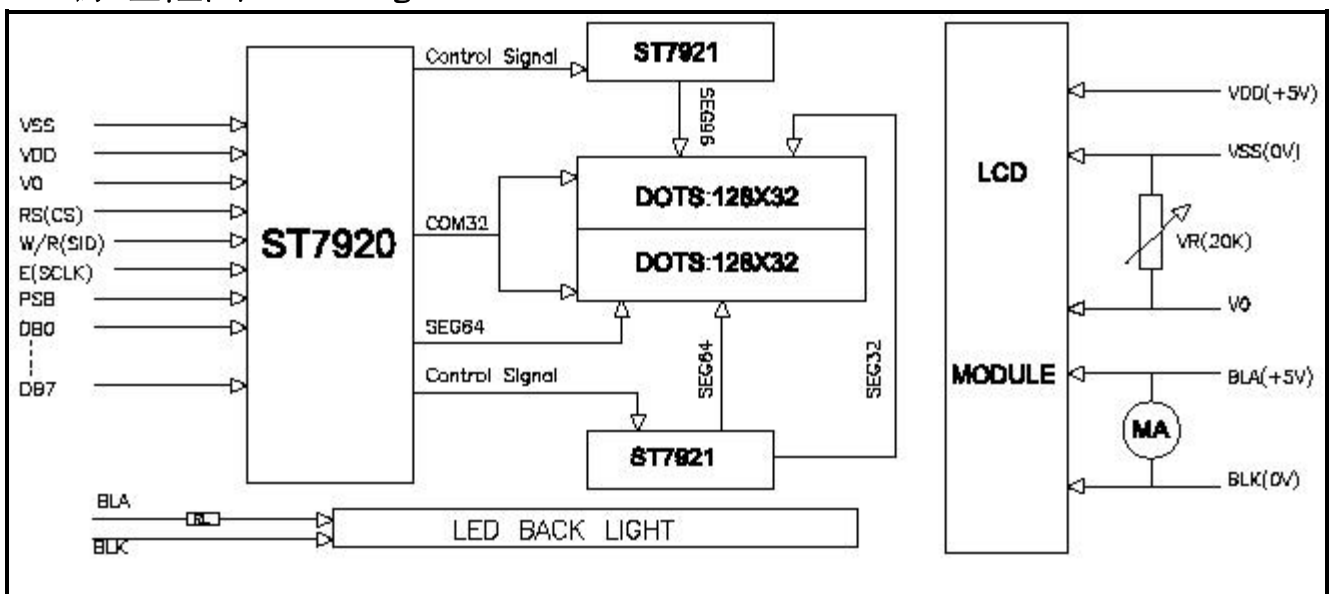

Note: when the temperature exceed 25°C, the approved current decrease rate for Backlight change as the temperature increase is: $-0.36 \times 30 \text{mA}/^\circ\text{C}$ (below 25°C, the current refer to constant, which would not hange with temperature).

4、模组外形图 Dimensional outline

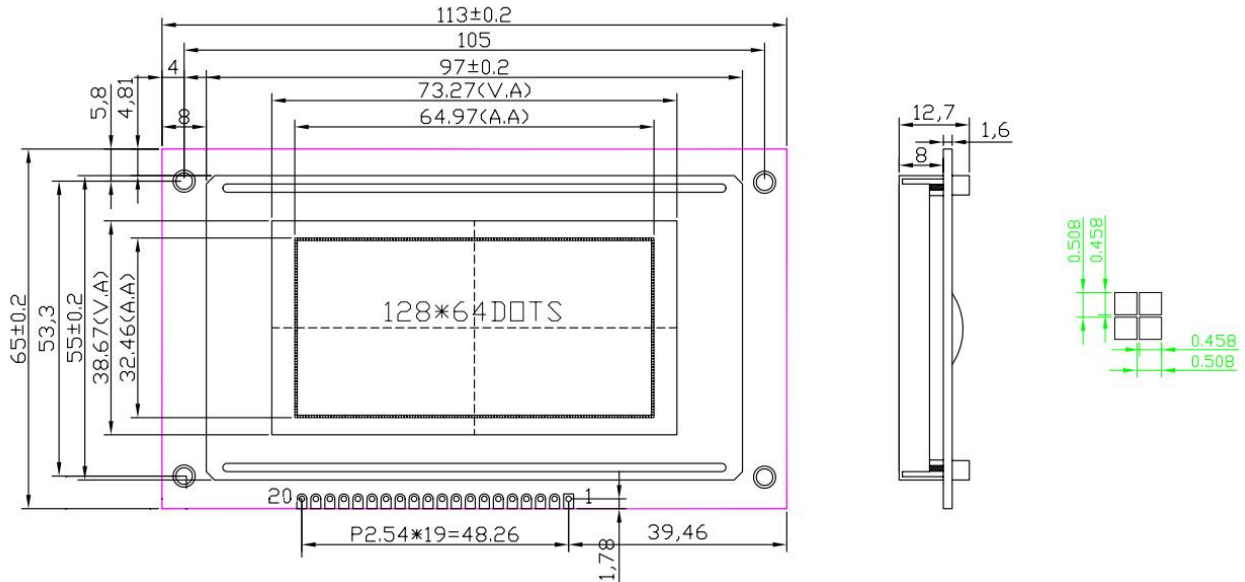

5、接口定义 Pin description

5. 1: PSB=H LCM 并口定义:

项目 Item	标号 Symbol	描述 Function
1	BLK	POWER Supply for backlight(-) (背光负极)
2	BLA	POWER Supply for backlight(+) (背光正极)
3	VSS	Power Ground 电源地(0V)
4	VDD	Power supply for Logic 电源正(+5V)
5	NO	No connection (空脚)
6	RS	Register selection (RS=H: 数据通道; RS=L: 指令通道)
7	R/W	Read/Write signal, R/W (数据读信号,低电平有效)
8	E	Enable select signal for chip 1(使能信号)
9~16	DB0~DB7	Data bus lines (数据总线)
17	PSB	Enable signal for Chip (PSB=H)

18	/RST	Reset signal (复位信号, 低电平有效)
19	VO	Power supply for the LCD drive 对比度调节端 (+4.85V 左右)
20	VOOUT	Position voltage output (正压输出+9.0V 或电源电压)

5. 2: PSB=L LCM 串口定义:

项目 Item	标号 Symbol	描述 Function
1	BLK	POWER Supply for backlight(-) (背光负极)
2	BLA	POWER Supply for backlight(+) (背光正极)
3	GND	Power Ground 电源地(0V)
4	VDD	Power supply for Logic 电源正(+5V)
5	NC	No connection (空脚)
6	CS	Enable select signal for chip 1(使能信号, 低电平有效)
7	SID	SPI SID line(串口数据线)
8	SCLK	SPI SCLK line(串口时钟线)
9~16	NC	No connection (空脚)
17	PSB	Enable signal for Chip (PSB=L)
18	/RST	Reset signal (复位信号, 低电平有效)
19	VO	Power supply for the LCD drive 对比度调节端 (+4.85V 左右)
20	VOOUT	Position voltage output (正压输出+9.0V 或电源电压)

6、极限参数 Absolute Maximum limit

项目 Item	符号 Symbol	最小值 MIN	最大值 MAX	单位 Unit
驱动电压 Supply Voltage for Logic	VDD	-0.3	5.5	V
LCD 电压 Supply Voltage for LCD	VLCD	VDD-10.0	VDD+0.3	V
输入电压 Input Voltage	Vin	-0.3	VDD+0.3	V
背光正向电流 Supply Current for Backlight	IF	---	80	mA
工作温度 Operating Temperature	Top	0	50	°C

储存温度 Storage Temperature	Tstr	-10	60	°C
-----------------------------	------	-----	----	----

7、电性参数 Electrical characteristics

项目 Item	符号 Symbol	条件 Condition	最小值 MIN	典型值 Typ	最大值 MAX	单位 Unit
逻辑电压 Supply Voltage for Logic	VDD-VSS	Ta = 25°C	4.75	5.0	5.25	V
输入高电压 Input High Voltage	VIH	Ta = 25°C	2.5	---	VDD	V
输入低电压 Input Low Voltage	VIL	Ta = 25°C	-0.3	---	0.6	V
输出高电压 Output High Voltage	VOH	Ta = 25°C	2.4	---	VDD	V
输出低电压 Output Low Voltage	VOL	Ta = 25°C	---	---	0.4	V
模块电流 Supply Current	IDD	Ta = 25°C	---	1.96	2.65	mA
背光电压 Supply Voltage for LED	VLED	IF=60mA	3.1	3.2	3.3	V

8、光电特性 Electro-Optical characteristics

项目 Item	标号 Symbol	条件 Condition	最小 MIN	典型 Typ	最大 MAX	单位 Unit
工作电压 Operating Voltage	Vop	Ta = 0°C	---	---	---	V
		Ta = +25°C	6.3	6.5	6.7	
		Ta = +50°C	---	---	---	
响应时间 Response time	Tr	Ta = 25°C	---	185	---	ms
	Tf		---	200	---	ms
对比度 Contrast Ratio	Cr	Ta = 25°C	---	3	---	---
视角范围 Viewing angle range	θ	Cr ≥ 2	-10	---	+40	deg
	Φ		-30	---	+30	deg

Definition of Operation Voltage (Vop)

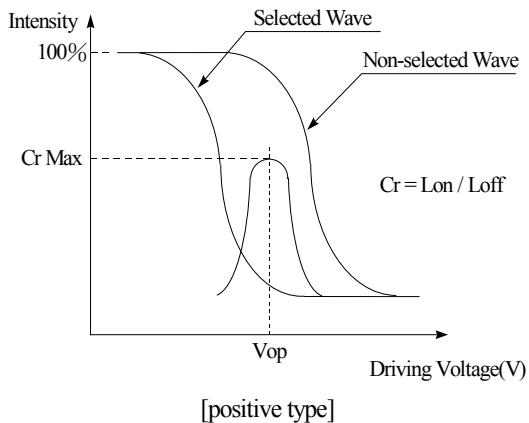

Definition of Response Time (Tr, Tf)

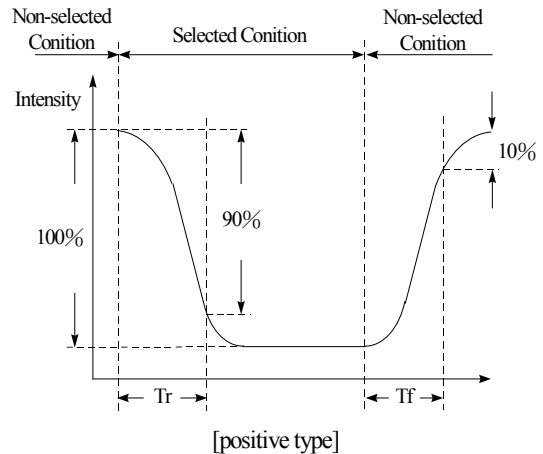

Conditions :

Operating Voltage : Vop Viewing Angle(θ , φ) : 0° , 0°
 Frame Frequency : 64 HZ Driving Waveform : 1/N duty , 1/a bias

Definition of viewing angle(CR \geq 2)

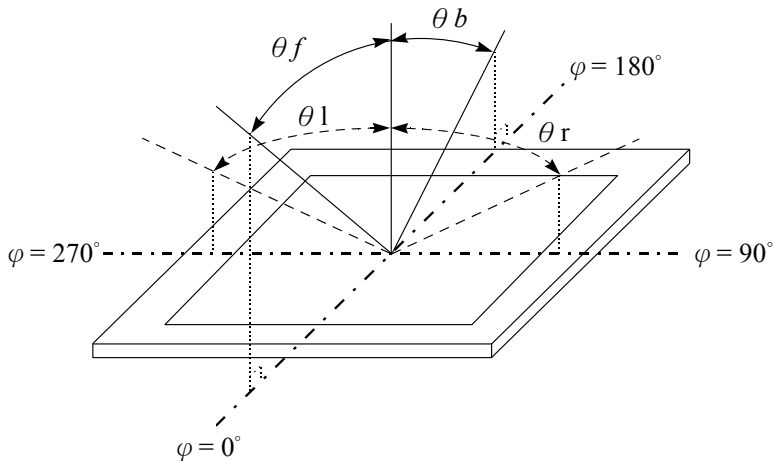

9、时序特性 Timing characteristics (8080 时序)

1).写模式 Read/Write mode(Writing/Reading Data from MPU to Controller)

并口时序

當PSB腳接高電位時，ST7920將進入並列模式，在並列模式下可由指令 **DL FLAG** 來選擇8-位元或4-位元介面，主控制系統將配合(RS, RW, E, DB0..DB7)來達成傳輸動作。

從一個完整的流程來看，當下設定位址指令後(CGRAM,DDRAM,IRAM.....)若要讀取資料時需先 DUMMY READ 一次才會讀取到正確資料第二次讀取時則不需 DUMMY READ 除非又下設定位址指令才需再次 DUMMY READ。

在4-位元傳輸模式中，每一個八位元的指令或資料都將被分為兩個位元組動作：較高4位元 (DB7~DB4) 的資料將會被放在第一個位元組的 (DB7~DB4) 部分，而較低4位元 (DB3~DB0) 的資料則會被放在第二個位元組的 (DB7~DB4) 部分，至於相關的另四位元則在4-位元傳輸模式中DB3~DB0介面未使用。

相關介面傳輸訊號請參考下圖說明：

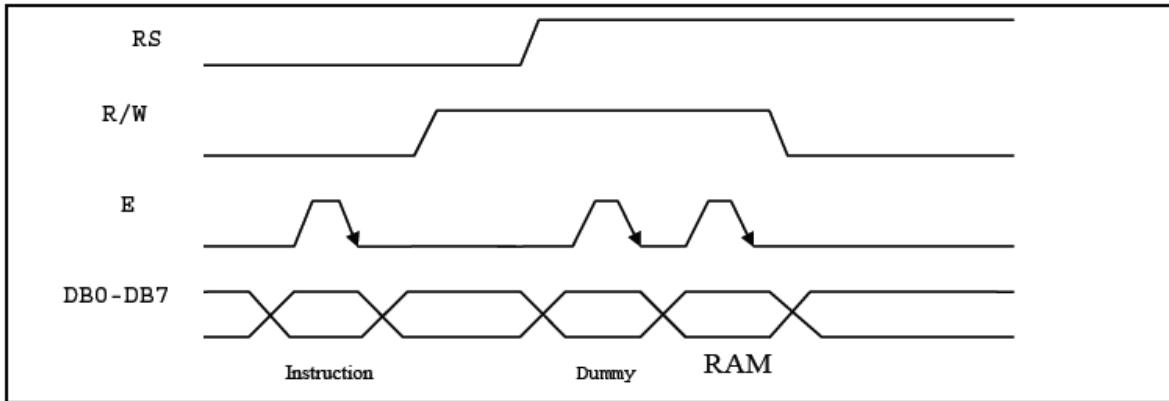

Timing Diagram of 8-bit Parallel Bus Mode Data Transfer

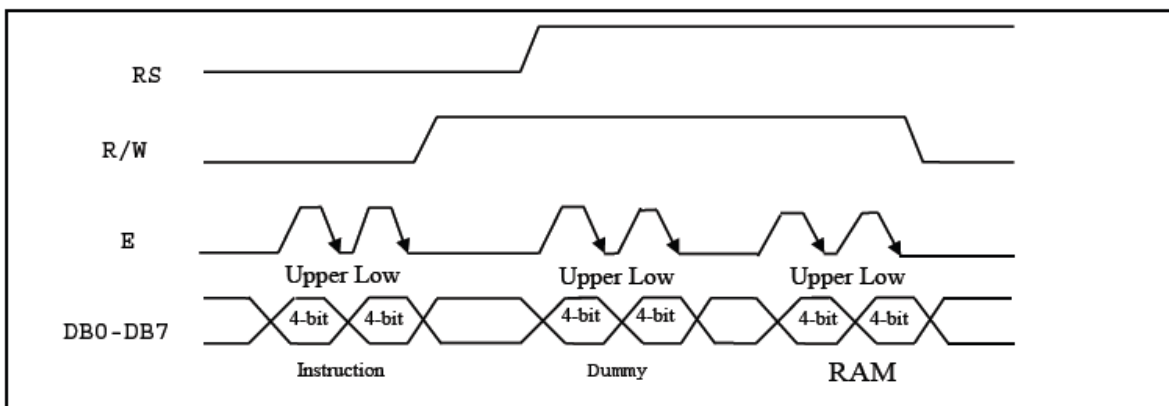

Timing Diagram of 4-bit Parallel Bus Mode Data Transfer

8-位元介面時序圖

● MPU寫資料到ST7920

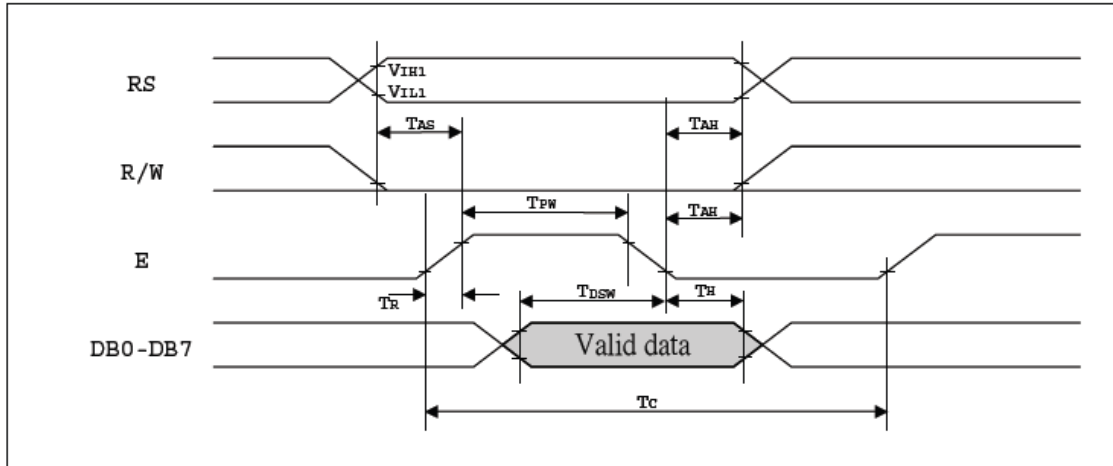

● MPU從ST7920讀出資料

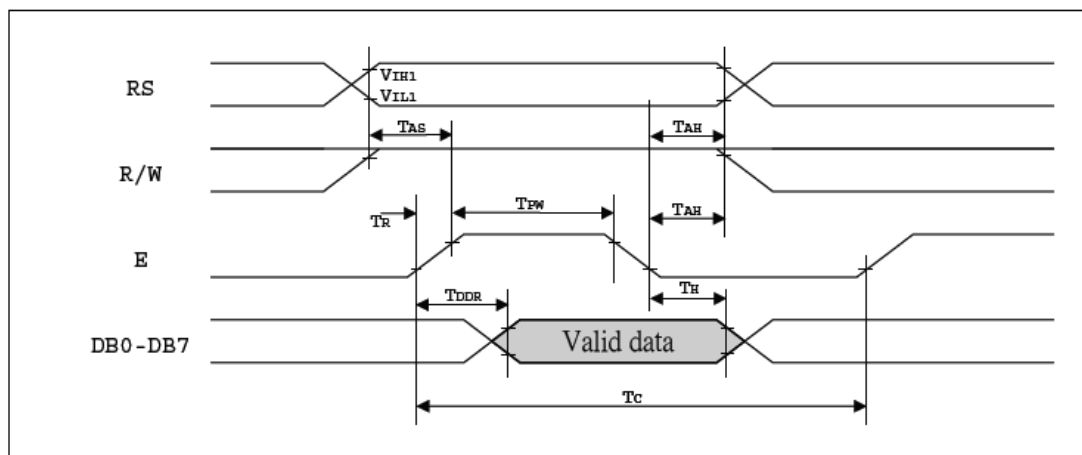

AC Characteristics ($T_A = 25^\circ\text{C}$, $V_{DD} = 4.5\text{V}$) Serial Mode Interface

Symbol	Characteristics	Test Condition	Min.	Typ.	Max.	Unit
<i>Internal Clock Operation</i>						
f_{OSC}	OSC Frequency	R = 33K Ω	470	530	590	KHz
<i>External Clock Operation</i>						
f_{EX}	External Frequency	-	470	530	590	KHz
	Duty Cycle	-	45	50	55	%
T_R, T_F	Rise/Fall Time	-	-	-	0.2	μs
TSCYC	Serial clock cycle	Pin E	400	-	-	ns
TSHW	SCLK high pulse width	Pin E	200	-	-	ns
TSLW	SCLK low pulse width	Pin E	200	-	-	ns
TSDS	SID data setup time	Pins RW	40	-	-	ns
TSDH	SID data hold time	Pins RW	40	-	-	ns
TCSS	CS setup time	Pins RS	60	-	-	ns
TCSH	CS hold time	Pins RS	60	-	-	ns

串口时序

當PSB腳接低電位時，ST7920將進入串列模式，在串列模式下將使用兩條資料傳輸線作串列資料的傳送，主控制系統將配合傳輸同步時脈線（SCLK）與接收串列資料線（SID），來達成串列傳輸的動作。

當需要同時連接數顆ST7920晶片時，晶片選擇腳（CS）將要被配合使用，在晶片選擇腳（CS）設為高電位時，同步時脈線（SCLK）輸入的訊號才會被接收，另一方面，當晶片選擇腳（CS）設為低電位時，ST7920的內部串列傳輸計數與串列資料將會被重置，也就是說在此狀態下，傳輸中的資料將被終止清除，並且將待傳輸的串列資料計數重設回第一位元；在一個最小的系統架構下，由一個微處理器連接控制單一個ST7920晶片時，相關的連接介面只需要使用同步時脈線（SCLK）與接收串列資料線（SID）兩隻腳，在這個模式下晶片選擇腳（CS）將被固定接到高電位。

ST7920的同步時脈線（SCLK）具有獨立的操作時脈，但是當有連續多個指令需要被傳送時，指令執行的時間將需要被考慮，必須確實等到前一個指令完全執行完成才能傳送下一筆資料，因為ST7920內部並沒有傳送/接收緩衝區。

從一個完整的串列傳輸流程來看，一開始先傳輸啓始位元組，它需先接收到五個連續的“1”（同步位元字串）在啓始位元組，此時傳輸計數將被重置並且串列傳輸將被同步，再跟隨的兩個位元字串分別指定傳輸方向位元（RW）及暫存器選擇位元（RS），最後第八的位元則為“0”。

在接收到同步位元及RW和RS資料的啓始位元組後，每一個八位元的指令將被分為兩個位元組接收到：較高4位元（DB7~DB4）的指令資料將會被放在第一個位元組的LSB部分，而較低4位元（DB3~DB0）的指令資料則會被放在第二個位元組的LSB部分，至於相關的另四位元則都為0。

串列傳輸訊號請參考下圖說明：

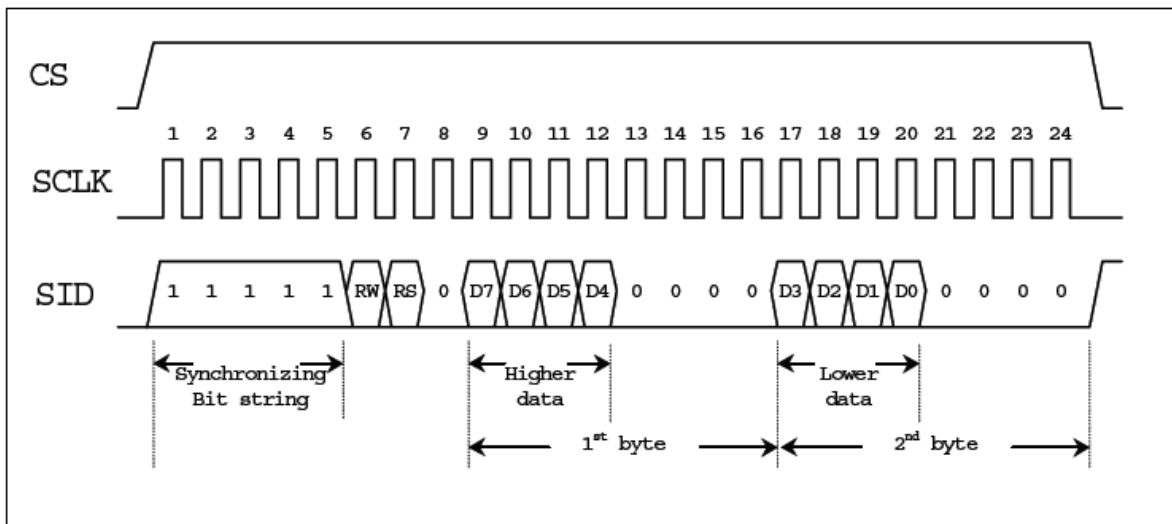

Timing Diagram of Serial Mode Data Transfer

串列介面時序圖

- MPU寫資料到ST7920

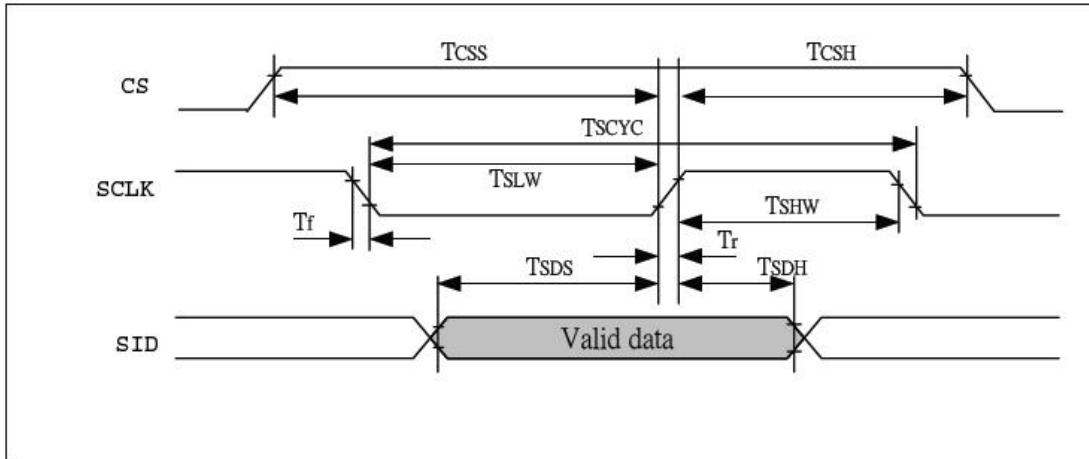

AC Characteristics (T_A = 25°C, V_{DD} = 2.7V) Serial Mode Interface

Symbol	Characteristics	Test Condition	Min.	Typ.	Max.	Unit
<i>Internal Clock Operation</i>						
f _{osc}	OSC Frequency	R = 18KΩ	470	530	590	KHz
<i>External Clock Operation</i>						
f _{ex}	External Frequency	-	470	530	590	KHz
	Duty Cycle	-	45	50	55	%
T _R , T _F	Rise/Fall Time	-	-	-	0.2	μs
TSCYC	Serial clock cycle	Pin E	600	-	-	ns
TSHW	SCLK high pulse width	Pin E	300	-	-	ns
TSLW	SCLK low pulse width	Pin E	300	-	-	ns
TSDS	SID data setup time	Pins RW	40	-	-	ns
TSDH	SID data hold time	Pins RW	40	-	-	ns
TCSS	CS setup time	Pins RS	60	-	-	ns
TCSH	CS hold time	Pins RS	60	-	-	ns

外部触发时序说明:

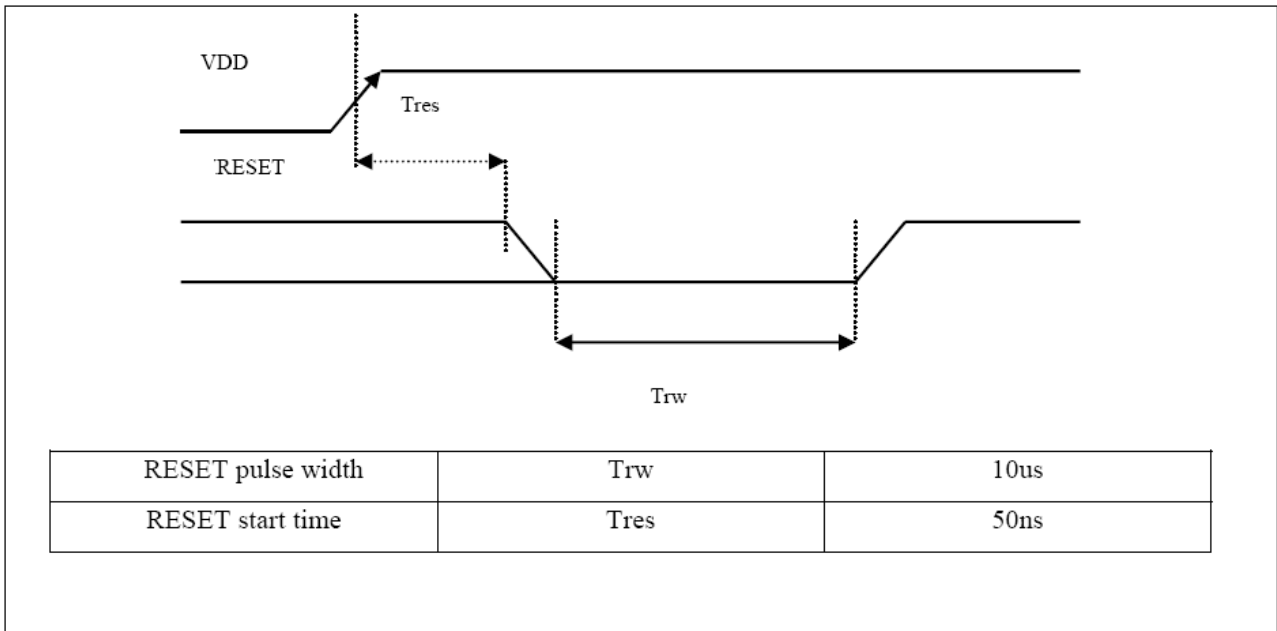

板载复位电路: C =0.1uf, R =10K

10.指令程序显示 Program instruction

指令	指令碼										說明	執行時間 (540KHZ)
	RS	RW	DB7	DB6	DB5	DB4	DB3	DB2	DB1	DB0		
待命模式	0	0	0	0	0	0	0	0	0	1	進入待命模式，執行任何其他指令都可終止待命模式 (Com1..32 停止動作,只保留 Com33 ICON 顯示)	72 us
捲動位址或 RAM 位址 選擇	0	0	0	0	0	0	0	0	0	1	SR=1: 允許輸入垂直捲動位址 SR=0: 允許輸入 IRAM 位址(擴充指令) SR=0: 允許設定 CGRAM 位址(基本指令)	72 us
反白選擇	0	0	0	0	0	0	0	1	R1	R0	選擇 4 行中的任一行作反白顯示，並可決定反白與否 R1,R0 初值為 00 當第一次設定時為反白顯示在一次設定時為正常顯示	72 us
睡眠模式	0	0	0	0	0	0	1	SL	X	X	SL=1: 脫離睡眠模式 SL=0: 進入睡眠模式	72 us
擴充 功能設定	0	0	0	0	1	DL	X	1	RE	G	DL=1 8-BIT 控制介面 DL=0 4-BIT 控制介面 RE=1: 擴充指令集動作 RE=0: 基本指令集動作 G=1 :繪圖顯示 ON G=0 :繪圖顯示 OFF	72 us
設定 IRAM 位址 或捲動位址	0	0	0	1	AC5	AC4	AC3	AC2	AC1	AC0	SR=1: AC5~AC0 為垂直捲動位址 SR=0: AC3~AC0 為 ICON RAM 位址	72 us
設定繪圖 RAM 位址	0	0	1	0	0	0	AC3	AC2	AC1	AC0	設定 GDRAM 位址到位址計數器 (AC) 先設垂直位址再設水平位址(連續寫入兩個位元組的資料來完成垂直與水平的座標位址) 垂直位址範圍 AC6...AC0 水平位址範圍 AC3...AC0	72 us

備註：

1. 當 ST7920 在接受指令前，微處理器必須先確認 ST7920 內部處於非忙碌狀態，即讀取 BF 旗標時 BF 需為 0，方可接受新的指令；如果在送出一個指令前並不檢查 BF 旗標，那麼在前一個指令和這個指令中間必須延遲一段較長的時間，即是等待前一個指令確實執行完成，指令執行的時間請參考指令表中的個別指令說明。
2. “RE” 為基本指令集與擴充指令集的選擇控制位元，當變更“RE”位元後，往後的指令集將維持在最後的狀態，除非再次變更“RE”位元，否則使用相同的指令集時，不需每次重設“RE”位元。

11. 品质保证 Quality Assurance

• Our company is qualified through ISO9001:2008 (Certificate NO.: 04910Q10923R0S). Our production plant has stringent quality control to guarantee absolute product quality. release and acceptance of finished LCM products in order to guarantee the quality required by the customer.

1 • Scope

The criteria are applicable to all the LCM products manufactured by TCC, either supplied alone or embedded in or integrated with other components.

2 • Inspection Apparatuses

Function testers, vernier calipers, microscopes, magnifiers, ESD wrist straps, finger cots, labels, ovens for high-low temperature tests, refrigerators, constant voltage power supply (DC) , desk lamps, etc.

3 • Reference Standards

3.1.1 GB/T 1619.96 Test Methods for TN LCD.

3.1.2 GB/T 12848.91 General Specifications for STN LCD.

3.1.3 GB2421-89 Basic Environmental Test Procedures for Electrical and Electronic Products

3.1.4 IPC-A-610C Acceptance Condition for Electrical Assemblies.

3.1.5 IEC-61000-4-2 Electrostatic Discharge immunity Tests

3.1.6 CISPR 22 Class B Conductive & Radiation limits

4 • Inspection Conditions and Inspection Reference

4.1 Cosmetic inspection: shall be done normally at $25\pm 5^{\circ}\text{C}$ of the ambient temperature and $45\pm 20\%\text{RH}$ of relative humidity, under the ambient luminance greater than $300\text{cd}/\text{cm}^2$ and at the distance of 30cm apart between the inspector' s eyes and the LCD panel and normally in reflected light. For back-lit LCMs, cosmetic inspection shall be done under the ambient luminance less than $100\text{cd}/\text{cm}^2$ with the backlight on.

4.2 The LCM shall be tested at the angle of 45° , left and right, and $0-45^{\circ}$, top and bottom (for STN LCM, at $20-55^{\circ}$) .

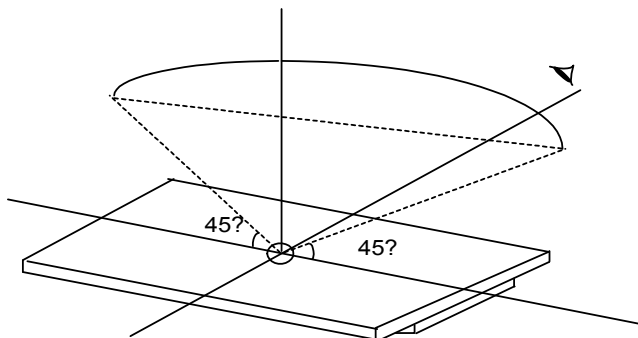

4.3 Definition of VA

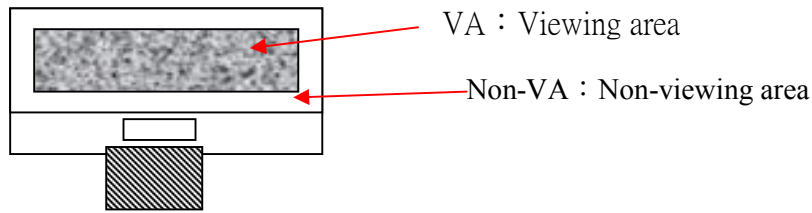

4.4 Inspection with naked eyes (exclusive of the inspection of the physical dimensions of defects carried out with magnifiers) .

4.5 Electrical properties

Inspection with the test jigs against the product specifications or drawings; display contents and parameters shall conform to those of the product specifications and the display effect to the sample.

4.5.1 Test voltage (V) :

4.5.1.1 (Determined) according to the operating instruction of test jigs assuming the external circuit can be adjusted unless the customer otherwise specifies driving voltage(s). (Display) effects are controlled within the specified range of voltage variation (If no specific requirements, display effects are controlled at $V_{op} = 9V$ or $V_{op} \pm 0.3V$ when V_{op} is below 9V; if V_{op} is above 9V, display effects are controlled at $V_{op} \pm 0.3\%$ at least). For display products with the customer-specified fixed V_{op} , display effects are controlled by adjusting the internal circuit; if necessary, acceptable limit samples shall be built.

4.5.2 Current Consumption (I) : refer to approved product specifications or drawings.



5 · Defects and Acceptance Standards

5.1 Dimensions : the outline dimensions and the dimensions that could influence the assembly at the customer' s side shall conform to those on the approved drawings.

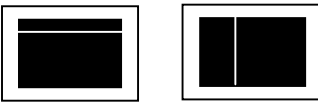
5.2 Main Defects - Functionality Tests:

No.	Item	Description	MAJ	MIN	Acceptance Criteria
5.2.1	Missing Segments	Missing segments or dots caused by broken contact(s), loose connection or an internal open circuit. 	√		Rejected
5.2.3	No display /Inaction	No segments, icons or graphics are displayed when the LCM is connected correctly.	√		Rejected
5.2.4	Mis-Display	Display pattern is deformed or jumbled-up	√		Rejected

SPECIFICATION FOR LCM MODULE

		under the normal scanning procedure.			
5.2.5	Wrong viewing angle	When powered up, the viewing angle at which the display is at its clearest is different from the required viewing angle or that of the approved samples.)	√		Rejected
5.2.6	Dim or Dark Display	Overall contrast is either too dark or too dim under normal operation.	√		If out of the voltage tolerance, Rejected
5.2.7	Slow response	Local response time varies when LCM is turned on or off.	√		Rejected
5.2.8	Extra segments, rows, or columns	Icons, traces, rows or columns that should not appear on the LCD screen and caused by LCD panel misalignment or insufficient corrosion.		√	Refer to dot/line standard
5.2.9	Dim segment	Under the normal voltage, the contrast of vertical and horizontal segments is uneven.		√	Reject or refer to samples
5.2.10	PI black/white spots	Partial black and white spots visible when changing display contents due to defective PI layer.		√	refer to the spot/line criteria for the visible spots when display image remains still; others OK.
5.2.11	pinhole/white spots	Deformed patterns appearing when LCD is turned on caused by missing ITO.  $d = (X+Y)/2$		√	refer to spot/line standard
5.2.12	Pattern distortion	Segment is either wider , narrower or deformed than the specified, caused by panel misalignment, resulting in unwanted heave(s) or missing: $ Ia-Ib \leq 1/4W$ (W is the normal width) 		√	Acceptable $ Ia-Ib > 1/4W$, rejected
5.2.13	High current	LCM current is larger than the designed value.		√	Rejected

5.3 LCD Visual Defects

5.3.1 Spot defect (defined within VA, spots out of VA do not count.)

Defect	Average diameter (d)	Acceptable quantity	MAJ	MIN
Spot defect (black spot, foreign matter, nick, scratches, including LC mis-orientation.)	$d \leq 0.2$	3		√
	$0.2 < d \leq 0.25$	2		
	$0.25 < d \leq 0.30$	1		

5.3.2 Line defects (defined within VA; those out of VA do not count.)

Defect	Length(L)	Width(W)	Acceptable quantity	MAJ	MIN
line defects (scratches, linear foreign matter) 	≤ 5.0	≤ 0.02	3		√
	≤ 3.0	≤ 0.03	3		
	≤ 3.0	≤ 0.05	1		

note : 1.If the width is bigger than 0.1mm, it shall be treated as spot defect.

5.3.3 Polarizer air bubble (defined within VA; those out of VA do not count.)

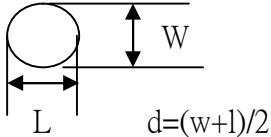
Defect	Average diameter (d)	Acceptable quantity	MAJ	MIN
Polarizer air bubble, Concave-Convex dot. 	$d \leq 0.3$	3		√
	$0.3 < d \leq 0.5$	2		
	$0.5 < d \leq 0.8$	1		

5.4 Backlight

No.	Item	Description	MAJ	MIN	Accept standard
5.4.1	Backlight not working, wrong color	/	√		Rejected
5.4.2	Color deviation	When powered on, the LCD color differs from that of the sample and is found after testing not conforming to the drawing.		√	Refer to sample and drawing
5.4.3	Brightness deviation	When powered on, the LCD brightness differs from that of the sample and is found after testing not conforming to the drawing; or if conforming to the drawing but		√	Refer to sample and drawing

SPECIFICATION FOR LCM MODULE

		over±30%.			
5.4.4	Uneven brightness	When powered on, the LCD brightness is uneven on the same LCD and out of the specification of the drawing.		√	Refer to sample and drawing
5.4.5	Spot/line scratch	Appearance of spot or line scratches on the LCD when turned on.		√	Refer to 6.3.1/6.3.2

5.5 Metal frame (Metal Bezel)

No.	Item	Description	MAJ	MIN	Accept standard
5.5.1	Material/surface treatment	Metal frame/surface treatment do not conform to the specifications.	√		Rejected
5.5.2	Tab twist inconformity/ Tab not twisted	Wrong twist method or direction and twist tabs are not twisted as required.	√		Rejected
5.5.3	Oxidization, chapped paint, discoloration, dents, and scratches	Oxidation on the surface of the metal bezel ; the quantity of spot defect (chapped front surface paint and substrate-exposing scratches) ≤0.8mm exceeds 3; the quantity of linear defects with the length ≤5.0mm and width ≤0.05mm exceeds 2; the quantity of spot defect (front dent, bubble, side surface chapped paint and substrate-exposing scratches)≤1.0mm exceeds 3; the quantity of linear defects with the width ≤0.05mm exceeds 3.		√	Rejected
5.5.4	Burr	Burr(s) on metal bezel is so long as to get into viewing area.		√	Rejected

5.6 SMT (Refer to IPC-A-610C if not specified)

No.	Item	Description	MAJ	MIN	Accept standard
5.6.1	Soldering solder defects	Cold, false and missing soldering, solder crack and insufficient solder dissolution.		√	Rejected
5.6.2	Solder ball/splash	Solder ball/tin dross causing short at the solder point.		√	Rejected
5.6.3	DIP parts	Floated or tilted DIP parts , keypad , connectors.		√	Rejected

— SPECIFICATION FOR LCM MODULE —

5.6.4	Solder shape	The welded spot should be concave and excessive or insufficient solder or solder burr on the welded spot must be rejected.	√	Rejected
5.6.5	Component pin exposure	For the DIP type components, 0.5~2mm component pin must be remained after cutting the soldered pin, and the solder surface should not be damaged nor should the component pin is fully covered with solder; otherwise rejected.	√	Reject
5.6.6	Poor Appearance	Caused by yellow-brown or black solder flux or resin or the white mist at the solder point caused by PCB cleaning.	√	reject

6 · Reliability test

Test item	Condition	Time(hrs)	Acceptance standard
High Storage Temp.	60°C	120	Functions and appearance are qualified before and after test
High Operating Temp.	50°C	120	
Low Storage Temp.	-10°C	120	
Low Operating Temp.	0°C	120	
Temp& Humidity Test	40°C/ 90%RH	120	
Thermal Shock	0°C ← 25°C → +50°C (30 min ← 5 min → 30min)	10 cycles	

Notes : ①Reliability tests shall be done as required by the customer if they inform TCC of their special requirements when starting a project.

②Storage test at high-low temperature and functionality test shall be done with reference to the specified temperature range.

③Test conditions shall be controlled at the permissible tolerance of $\pm 5^{\circ}\text{C}$.

7 · Packing

Guarantee to offer ESD shield bag to protect the product from electrostatic or magnetic interference during delivery

8 · Others

8.1 Items not specified in this document or released on compromise should be inspected with reference to the mutual agreement and limit samples.

12. 注意事项 Precaution for using LCD/LCM

After reliability test, recovery time should be 24 hours minimum. Moreover, functions, performance and appearance shall be free from remarkable deterioration within 50,000 hours (average) under ordinary operating and storage conditions room temperature ($20\pm 8^{\circ}\text{C}$), normal humidity (below 65% RH), and in the area not exposed to direct sun light. Using LCM beyond these conditions will shorten the life time.

Precaution for using LCD/LCM

LCD/LCM is assembled and adjusted with a high degree of precision. Do not attempt to make any alteration or modification. The followings should be noted.

General Precautions:

1. LCD panel is made of glass. Avoid excessive mechanical shock or applying strong pressure onto the surface of display area.
2. The polarizer used on the display surface is easily scratched and damaged. Extreme care should be taken when handling. To clean dust or dirt off the display surface, wipe gently with cotton, or other soft material soaked with isopropyl alcohol, ethyl alcohol or trichlorotrifluoroethane, do not use water, ketone or aromatics and never scrub hard.
3. Do not tamper in any way with the tabs on the metal frame.
4. Do not make any modification on the PCB without consulting TCC.
5. When mounting a LCM, make sure that the PCB is not under any stress such as bending or twisting. Elastomer contacts are very delicate and missing pixels could result from slight dislocation of any of the elements.
6. Avoid pressing on the metal bezel, otherwise the elastomer connector could be deformed and lose contact, resulting in missing pixels and also cause rainbow on the display.
7. Be careful not to touch or swallow liquid crystal that might leak from a damaged cell. Any liquid crystal adheres to skin or clothes, wash it off immediately with soap and water.

Static Electricity Precautions:

1. CMOS-LSI is used for the module circuit; therefore operators should be grounded whenever he/she comes into contact with the module.
2. Do not touch any of the conductive parts such as the LSI pads; the copper leads on the PCB and the interface terminals with any parts of the human body.
3. Do not touch the connection terminals of the display with bare hand; it will cause disconnection or defective insulation of terminals.
4. The modules should be kept in anti-static bags or other containers resistant to static for storage.

5. Only properly grounded soldering irons should be used.
6. If an electric screwdriver is used, it should be grounded and shielded to prevent sparks.
7. The normal static prevention measures should be observed for work clothes and working benches.
8. Since dry air is inductive to static, a relative humidity of 50-60% is recommended.

Soldering Precautions:

1. Soldering should be performed only on the I/O terminals.
2. Use soldering irons with proper grounding and no leakage.
3. Soldering temperature: $350^{\circ}\text{C} \pm 10^{\circ}\text{C}$
4. Soldering time: 3 to 4 second.
5. Use eutectic solder with resin flux filling.
6. If flux is used, the LCD surface should be protected to avoid spattering flux.
7. Flux residue should be removed.

Operation Precautions:

1. The viewing angle can be adjusted by varying the LCD driving voltage V_o .
2. Since applied DC voltage causes electro-chemical reactions, which deteriorate the display, the applied pulse waveform should be a symmetric waveform such that no DC component remains. Be sure to use the specified operating voltage.
3. Driving voltage should be kept within specified range; excess voltage will shorten display life.
4. Response time increases with decrease in temperature.
5. Display color may be affected at temperatures above its operational range.
6. Keep the temperature within the specified range usage and storage. Excessive temperature and humidity could cause polarization degradation, polarizer peel-off or generate bubbles.
7. For long-term storage over 40°C is required, the relative humidity should be kept below 60%, and avoid direct sunlight.

Limited Warranty

TCC LCDs and modules are not consumer products, but may be incorporated by TCC' s customers into consumer products or components thereof, TCC does not warrant that its LCDs and components are fit for any such particular purpose.

1. The liability of TCC is limited to repair or replacement on the terms set forth below. TCC will not be responsible for any subsequent or consequential events or injury or damage to any personnel or user including third party personnel and/or user. Unless otherwise agreed in writing between TCC and the customer, TCC will only replace or repair any of its LCD which is found defective electrically or visually when inspected in accordance with TCC general LCD inspection standard . (Copies available on request)
2. No warranty can be granted if any of the precautions state in handling liquid crystal display above has been disregarded. Broken glass, scratches on polarizer mechanical damages as well as defects that are caused accelerated environment tests are excluded from warranty.
3. In returning the LCD/LCM, they must be properly packaged; there should be detailed description of the failures or defect.

13. 参考程序 Reference Program for LCD Modules

1). Module interface to MPU 接线图

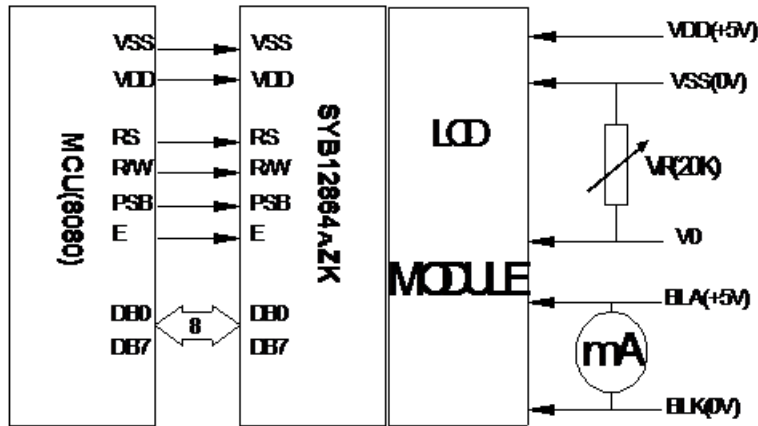

2). Reference Program 参考程序

(参考 ST7920 芯片资料)

```
#include <reg52.h>
#include <intrins.h>
#define lcd_data    P0
/*syb12864Azk 端口定义*/
#define LCD_data    P0           //数据口
sbit LCD_RS    =  P2^0;         //寄存器选择输入 35
sbit LCD_RW    =  P2^1;         //液晶读/写控制 36
sbit e1=P2^7;
unsigned char code AC_TABLE[];
/*****
函数: void lcd_busy()
功能: 读忙函数
*****/
void lcd_busy()
{
    LCD_data=0xff;
    LCD_RS = 0;
    LCD_RW = 1;
    e1=0;
    while(LCD_data&0x80);
    e1=1;
}
/*****
函数: void lcd_cmdwrite(uchar cmd)
```

功能：写指令数据到 LCD

*****/

```
void lcd_cmdwrite(uchar cmd)
```

```
{
    lcd_busy();
    LCD_RS = 0; //di
    LCD_RW = 0;
    e1=0;
    P0 = cmd;
    e1=1;
}
```

函数： void lcd_datawrite(uchar dat)

功能：写显示数据到 LCD

*****/

```
void lcd_datawrite(uchar dat)
```

```
{
    lcd_busy();
    LCD_RS = 1;
    LCD_RW = 0;
    e1=0;
    P0 = dat;
    e1=1;
}
```

LCD 初始化设定

*****/

```
void lcd_init()
```

```
{
    lcd_cmdwrite(0x36); //扩充指令操作
    lcd_cmdwrite(0x30); //基本指令操作
    lcd_cmdwrite(0x0C); //显示开，关光标
    lcd_cmdwrite(0x01); //清除 LCD 的显示内容
    lcd_cmdwrite(0x06); //指定在资料的读取及写入时，设定游标的移动方向及指定显示的移位
}
```

```
uchar code szh[]={"深圳叁元晶液晶显示科技有限公司"};
```

```
void display_hz(uchar row,uchar col,uchar code *puts)
```

```
{
    lcd_cmdwrite(0x30);
    lcd_cmdwrite(AC_TABLE[8*row+col]);
    while(*puts != '\0')
    {
        if(col==8)
```



```
    {
        col=0;
        row++;
    }
    if(row==4) row=0;
    lcd_cmdwrite(AC_TABLE[8*row+col]);
    lcd_datawrite(*puts);
    puts++;
    lcd_datawrite(*puts);
    puts++;
    col++;
}
}
void main()
{
    lcd_init(); //液晶初始化
    display_hz(0,0,"深圳三元晶液晶顯示科技有限公司");
    while(1);

}
}
```